

INSTRUCTION MANUAL



KEPCO An ISO 9001 Company.

CS 04

CHASSIS SLIDES MODEL CS 04

1. DESCRIPTION

Chassis Slides Model CS 04 contains the components required to install a pair of chassis slides on Kepco BOP High Power 1KW Power Supplies.

2. INSTALLATION OF CHASSIS SLIDES

2.1 MATERIAL REQUIRED (SEE TABLE 1.)

TABLE 1. MATERIAL REQUIRED

MATERIAL	LOCATION	QUANTITY
One pair of slides (includes cabinet and chassis sections), Kepco P/N 108-0318 (Jonathan P/N 110-20-QD-1)	Provided in this Kit	2
End Bracket, Kepco P/N 128-1849 (Jonathan P/N SPO-440-Z)	Provided in this Kit	4
Screw 10-32 x 3/8 in. long, BHPH, cadmium/yellow plated Kepco P/N 101-0311	Provided in this Kit	16
Nut, 10-32 Kepco P/N 102-0008	Provided in this Kit	8
Washer, flat #10 Kepco P/N 103-0031	Provided in this Kit	8
Washer, Internal lock, #10, Kepco P/N 103-0019	Provided in this Kit	8

2.2 PROCEDURE (SEE FIGURES 1, 2 AND 3.)

1. Attach two chassis sections of slide (108-0429) to each side of rack adapter using eight screws (101-0311) and eight washers (103-0019), four on each side (see Figure 1).

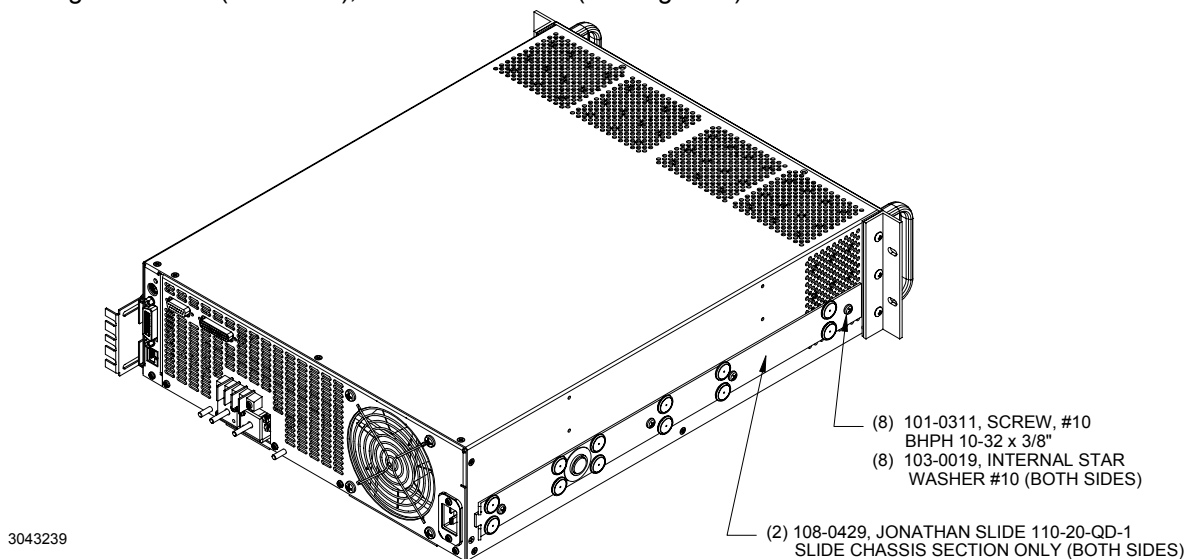

FIGURE 1. INSTALLING CHASSIS SLIDES ON RACK ADAPTER

KEPCO, INC. ● 131-38 SANFORD AVENUE ● FLUSHING, NY. 11355 U.S.A. ● TEL (718) 461-7000 ● FAX (718) 767-1102
<http://www.kepcopower.com> ● email: hq@kepcopower.com

- Attach four end brackets (128-1849) to the two cabinet sections of slides (108-0318) using eight screws (101-0311), flat washers (103-0031), lockwashers (103-0019), and nuts (102-0008) (see Figure 2).

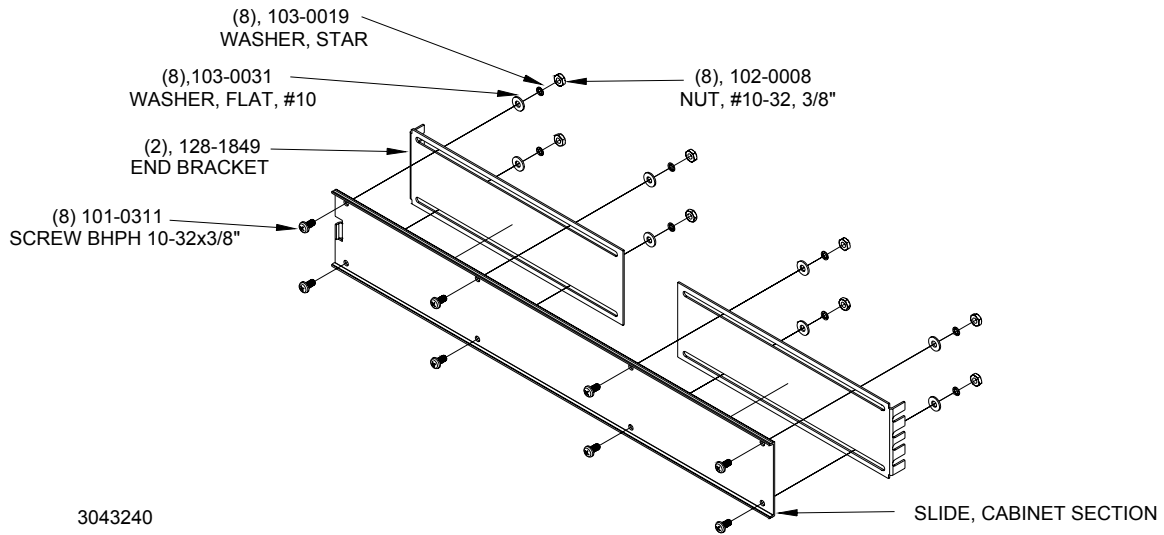

FIGURE 2. ATTACHING END BRACKETS TO SLIDE (CABINET SECTION)

- Attach mounting brackets (with cabinet section of slide attached) to the cabinet rail (attaching hardware not supplied) (see Figure 3).

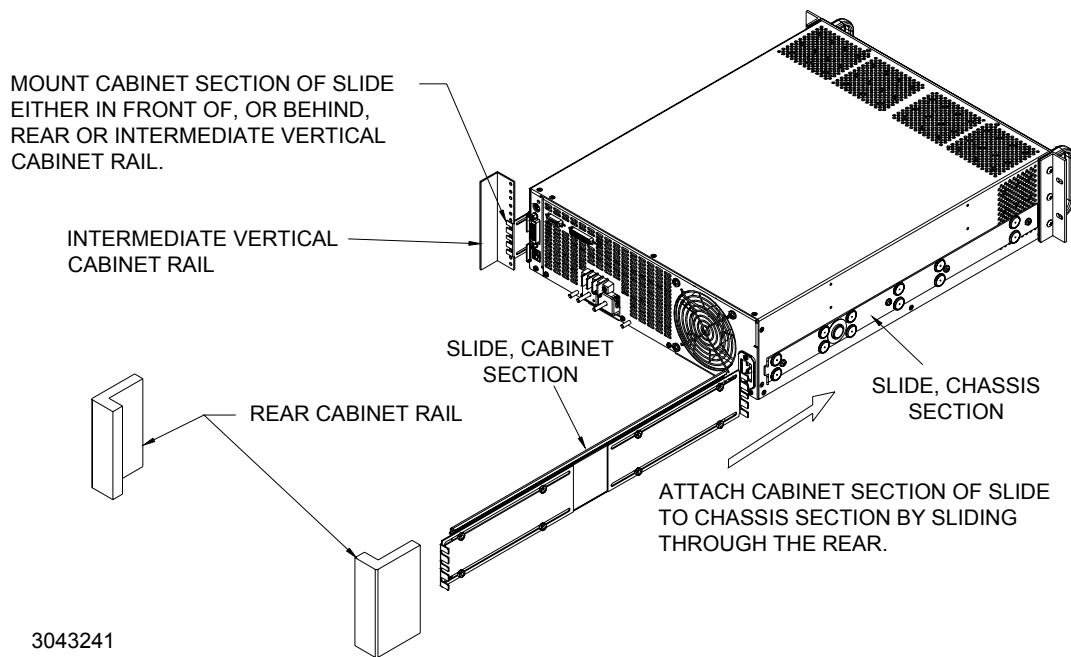

FIGURE 3. ATTACHING CABINET SECTION TO RAIL

- Insert power supply into rack (insert chassis-mounted slide section into the cabinet mounted slide section).